

**SINGLE AXIS PROGRAMMABLE TILT SWITCH
(0729-1727-99)**



OVERVIEW

The single axis programmable tilt switch incorporates an electrolytic tilt sensor and micro-controller technology. One of the special features is its ability to be field programmable by the user. It provides a wide-angle trip range and a wide operating supply voltage range. There are 2 open collector outputs to indicate trip points. The bi-directional output will trip in both directions from the center set point to the trip point. The unidirectional output will only trip in the programmed direction only. The center set point can be at any angle within the specified range of the unit. The unit will retain the programmed trip points even when the power is removed. It can be reprogrammed as often as necessary for multiple applications.

**SINGLE AXIS PROGRAMMABLE TILT SWITCH
(0729-1727-99)**

WIRING CONNECTIONS

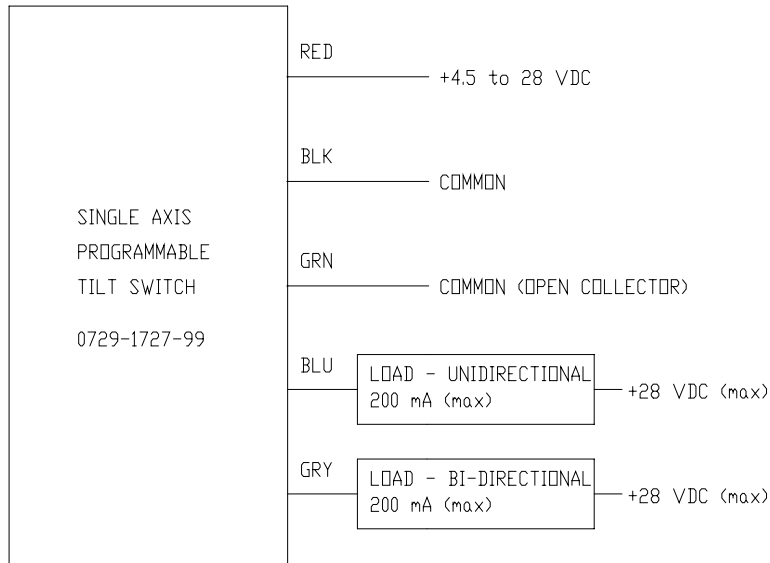

The diagram shows the connections to power and output. Observe all voltage and current limits. Do not exceed the open collector output current or the internal transistors can be damaged. The common (open collector – green wire) is only used if a separate power supply is used for the loads. This common (open collector – green wire) is internally connected the common (power supply – black wire).

**SINGLE AXIS PROGRAMMABLE TILT SWITCH
(0729-1727-99)**

PROGRAMMING

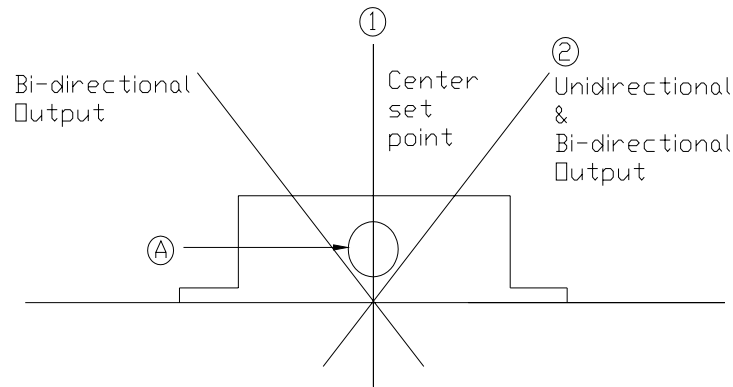

To program the tilt switch, remove the cap on the front of the unit (A). With no power applied to the unit, insert a jumper into the hole by shorting the 2 pins inside the unit. Position the unit to a center position within the specified range of the unit (1). This will be the center of the non-trip area. Apply power and wait at least 3 seconds. Next, tilt the unit to a position that you want the output to indicate a trip point (2). Remove the jumper and wait at least 3 seconds. This will be the unidirectional and bi-directional trip points. The bi-directional trip point will also trip at a point in the opposite angle from the center of the non-trip point. Remove power from the unit. Replace the cap on the front of the unit. The unit is now fully programmed. The unit will retain these values until it is reprogrammed. The unit can be reprogrammed as many times as needed for other trip positions.

**SINGLE AXIS PROGRAMMABLE TILT SWITCH
(0729-1727-99)**

SPECIFICATIONS

Electrical

Power supply voltage (range).....+4.5 to +28 VDC
Power supply current (typical).....1.0 mA @ 12VDC
Output (unidirectional).....200 mA max
Output (Bi-directional).....200 mA max
Output saturation voltage (typ).....1.0 volt
Cable length.....18.0" nom.
Output Delay.....0.5 sec.
Output Hysteresis..... 1.0° nom. (tripped to non-tripped direction only)

Connections

Red.....+4.5 to 28 VDC
Black.....Common
Green.....Common (OC)
Blue.....Open Collector (unidirectional)
Grey.....Open Collector (bi-directional)

Case Dimensions:

Length..... 2.00"
Width.....1.50"
Height.....0.750"
Flange Length.....3.00"
Flange Holes (centerline).....2.50"
Hole Diameter.....0.190"

Environmental

Temperature range
Operating*.....-40 to +85 ° C
Storage*.....-55 to +85 ° C

Performance Specifications

*Refer to the individual specification of the installed sensor.

**SINGLE AXIS PROGRAMMABLE TILT SWITCH
(0729-1727-99)**

Sensor Operating Specifications:

Tilt sensor part number.....0717-4304-99
Operating Range (max.)..... $\pm 45^\circ$
Repeatability..... 0.1°
Resolution..... < 0.2 arc minutes
Symmetry (typ.)..... 5%
Mech. Crosstalk / Deg. (to 20°)..... 0.025°
Temperature Coefficient
Null..... 20 arc sec / $^\circ\text{C}$
Scale..... 0.1% / $^\circ\text{C}$
Stability @ 24 Hrs..... 0.1°
Operating Temperature -40°C to $+85^\circ\text{C}$
Storage Temperature..... -55°C to $+100^\circ\text{C}$
Time Constant (1) ≤ 100 msec
Material magnetic

Power and signal connection guide

Caution: Observe polarity when connecting power input and signal outputs.

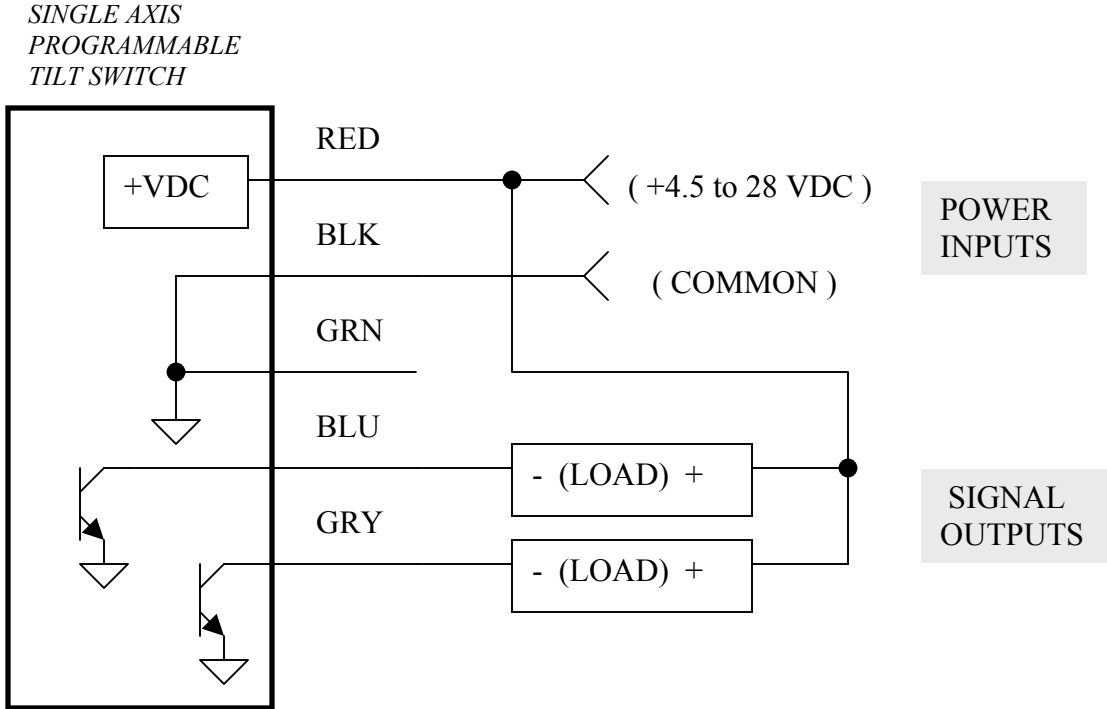

Typical power and output example

