

0729-1755-99

Dual Axis Inclinometer



Description

The dual axis inclinometer in a compact, high-impact plastic housing offers microprocessor based electronics with 0-5 V output for easy use and interface with instrumentation and equipment. Assembly includes the Fredericks dual axis TrueTilt 0717-4318-99 sensor which provides long term repeatability and environmental durability in the most demanding applications.

- Angle range +/-60° (X & Y axis)
- Resolution .003 degrees
- Repeatability +/-0.1 Degrees
- Outputs (X& Y Axis) Analog 0-5 Volts
PWM & Temperature
- Power Supply Voltage 7 to 16 VDC

Operating Specifications

Output	0-5 Volts
Angle Range	*+/-60° (X&Y axis)
Resolution (.003 degrees)	0.2 Arc Minutes
Repeatability	+/- 0.1 degrees
Power supply voltage	7 to 16 VDC (regulated)
Power supply current	20mA @ 7VDC
Operating temperature range	-40°C to + 85°C
Storage temperature range	-40°C to + 85°C
Symmetry (typ.)	5%
Null Offset	5.0°
Mech. Crosstalk / Deg. (to 20°)	0.025°
Temperature Coefficient	
Null	20 arc sec / °C
Scale	0.1% / °C
Stability @ 24 hrs	0.1°

Physical Dimensions

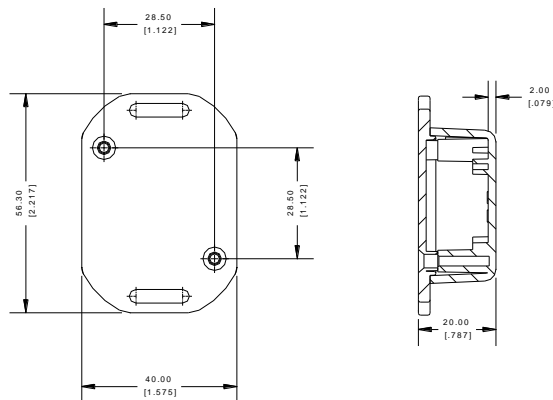

Top View of Assembly

Side View of Assembly

Applications Include

- Solar Tracking
- Aerial Lift Platforms
- Construction machines
- Alarm System Activation
- Medical positioning and monitoring
- Machine tool leveling
- Mobile and stationary cranes

Sensor Output Sensitivity Chart

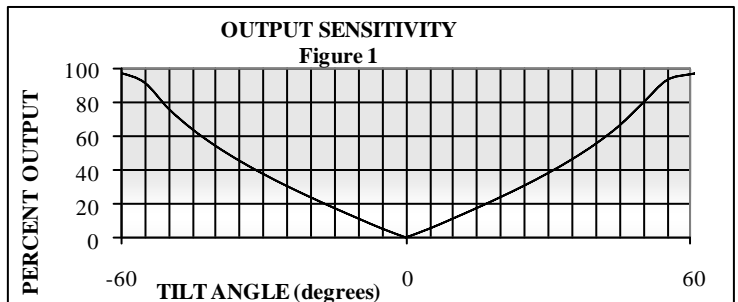

Circuit Board Specifications

Wire color	Signal name	Direction	Description
RED	Vcc	Input	Supply voltage input: +7 to + 16 vdc
BLK	GND	-	Ground – The reference for the digital signals and the supply voltage
YEL	Temperature	Output	Voltage output from the on board temperature sensor MCP9700 Note: To convert the voltage from the on board MCP9700 use the following formula; Temp C = (MCP9700 output voltage – 0.5)/0.010
GRN	X axis analog	Output	X axis voltage output- ratiometric with internal 5V regulated supply voltage. For example: Null (zero degrees of angle) = 2.5 volts with supply voltage at 5V
BLU	Y axis analog	Output	Y axis voltage output- ratiometric with internal 5V regulated supply voltage. For example: Null (zero degrees of angle) = 2.5 volts with supply voltage at 5V
N/C*	X axis PWM	Output	X axis PWM output – 122 Hz duty cycle, 16 bit resolution (1% to 99%) For example: Null (zero degrees of angle) = 50% modulation
N/C*	Y axis PWM	Output	Y axis PWM output – 122 Hz duty cycle, 16 bit resolution (1% to 99%) For example: Null (zero degrees of angle) = 50% modulation

Note: The analog voltage output circuit is integrated from the PMW output. This circuit will be sensitive to moisture. Protected environment or conformal coating may be needed in higher humidity conditions.

Note: Installed sensor is 0717-4318-99, other sensors can be utilized per customer request.

*Optional outputs can be provided upon request.