

Absolute Stand Alone Inclinometer

1. PRODUCT DESCRIPTION

The 0750 Series single and dual axis stand alone inclinometers utilize the proven capacitive 3D-MEMS sensing element technology and robust mechanics. This combination makes the modules suitable for e.g. heavy duty construction machines and industrial applications. The modules have a digital RS-485 interface.

The modules are approximately 30x30x13mm in size, and can be mounted with two M3 screws. Modules are equipped with a pigtail cable with open ends. The products are available for measuring ranges of $\pm 30^\circ$ and $\pm 90^\circ$.

Standard industrial RS-485 interface enables long transmission distances and possibility to connect multiple modules, with individual addresses, to the same bus. In addition to inclination, temperature information is also available from the module. The modules also feature a built-in self-test function that can be activated externally.

2. INSTALLATION and INITIALISATION

2.1 Mounting

The sensor module is to be mounted with 2 screws, dimension M4. Mounting torque is $5 \pm 1\text{Nm}$. Optional mounting bracket mounted with 2 screws, dimension M6. Mounting torque $10 \pm 2\text{Nm}$.

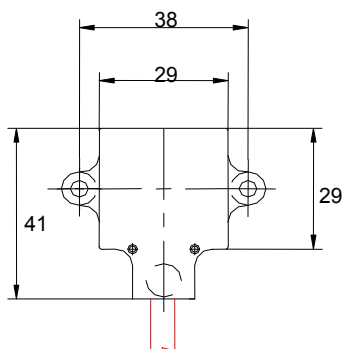

Figure 1. Dimensions

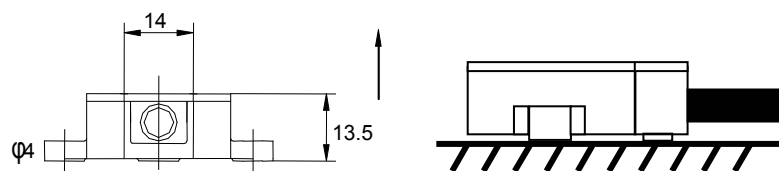

Figure 2. Mounting

2.2 Electrical connection

Electrical interface to the sensor is a robust PVC cable. Connection is done via 4 x AWG26 ($\varnothing 0,14\text{mm}$) leads.

Connection configuration:

Name	Function	Pigtail wire color
V _{cc}	Power supply	Red
GND	Ground	Blue
A	Bus connection	White
B	Bus connection	Yellow

2.2.1 Power supply

Supply voltage is connected to Red and Blue wires. The module needs a 7...35Vdc voltage to work properly. Normal current consumption is 15...20mA

2.2.2 Databus connection

Before connecting the modules to the bus, make sure they all have a different address (see 3.2.4.2 Command 81)

Typical connection presented in figure 3.

NOTE: RS485 cannot be connected directly to RS232 interface

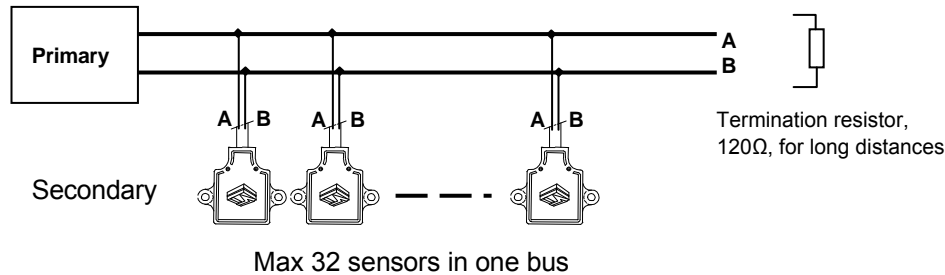

If communication fails to work, switch A and B polarity at Primary end.

2.3 Initialize the terminal software

For communication, please use e.g. Hyperterminal software (standard in MS Windows). The communication parameters are to be set as presented in the table below.

Fuction	Setting	Comments
baud rate	38400 (factory dafault)	Can be adjusted in the range of 1200...38400 bauds
Number of data bits	8	Fixed
No parity	N	Fixed
Number of stop bits	1	Fixed

2.4 Changing the parameter settings

2.4.1 Select the address for the module

The address selection (**Command 81**) is needed especially when more than one modules are connected to the system over same line.

All modules are configured to address 99 when delivered (factory setting). The address can be changed via software when the module is installed as a part of a system.

Please make sure that each module connected to same line has its individual address before installation. Two modules with same address will cause errors in operation.

2.4.2 Other selections (optional)

The parameters that can be selected or adjusted are:

Average rate in ave calculations (Command 85): This parameter sets the number of samples that is used in the average calculations (selection range starts from 2 with maximun of 100). The factory setting for the number of samples is 30.

Change baud rate (Command 88): This parameter sets the baud rate of the communication. The factory setting is 38400 baud.

Temperature coefficient (Command 84): This parameter is used to fine adjust the temperature measurement against a reliable temperature reference.

X axis zero offset value (Command 86): This parameter is used to fine adjust the X axis inclination measurement e.g. to zero the read out of the module after it is installed in the end product.

For the description of the adjustment method, please see Chapter 4.3.4.6.

Y axis zero offset value (Command 87): This parameter is used to fine adjust the Y axis inclination measurement e.g. to zero the read out of the module after it is installed in the end product.

For the description of the adjustment method, please see Chapter 4.3.4.7.

2.5 Reverting to factory settings

The module can be reverted back to the original factory settings with Command 89. This is useful e.g. if the track record of parameter changes performed is lost. For details, please see Chapter 4.3.4.9.

3. COMMANDS

3.1 Command ranges and formats

Range	Description	Format
10...18	Commands for X axis	*AddressCommand#
20...28	Commands for Y axis	*AddressCommand#
40...48	Commands for Temperature	*AddressCommand#
80...89	Commands for configuration settings	*AddressCommandPasswordParameters#

'Note! No spaces are used in the command lines to separate address, command, password or parameter.

3.2 Command descriptions

The following chapters give examples on the use of the commands. The module that is used in these examples is configured to the factory setting address 99.

3.2.1 Commands for X axis

Command description	Command	Output
X axis raw data	*9911#	03e3
X axis data in g	*9912#	-0.037g
X axis data in rad	*9913#	-0.039rad
X axis data in degrees	*9914#	-02.23°
X axis raw average data	*9915#	03e0
X axis average data in g	*9916#	-0.037g
X axis average data in rad	*9917#	-0.039rad
X axis average data in degrees	*9918#	-02.23°
X axis raw data with CRC	*9911C#	033a,02b3
X axis data in g with CRC	*9912C#	-0.126g,580d
X axis data in rad with CRC	*9913C#	-0.127rad,ac87
X axis data in degrees with CRC	*9914C#	-7.18°,6fc7
X axis raw average data with CRC	*9915C#	0336,328d
X axis average data in g with CRC	*9916C#	-0.123g,591d
X axis average data in rad with CRC	*9917C#	-0.124rad,acc3
X axis average data in degrees with CRC	*9918C#	-7.07°,90f6

CRC: see appendix 2.

The output for the raw data is in HEX, thus 03e3 equals to 995.

3.2.2 Commands for Y axis

Command description	Command	Output
Y axis raw data	*9921#	0409
Y axis data in g	*9922#	+0.009g
Y axis data in rad	*9923#	+0.010rad
Y axis data in degrees	*9924#	+00.56°
Y axis raw average data	*9925#	0408
Y axis average data in g	*9926#	+0.009g
Y axis average data in rad	*9927#	+0.007rad
Y axis average data in degrees	*9928#	+00.56°
Y axis raw data with CRC	*9921C#	03ec,7252
Y axis data in g with CRC	*9922C#	-0.012g,1d71
Y axis data in rad with CRC	*9923C#	-0.013rad,9f66
Y axis data in degrees with CRC	*9924C#	-0.72°,52e6
Y axis raw average data with CRC	*9925C#	03e7,b26c
Y axis average data in g with CRC	*9926C#	-0.015g,dcc0
Y axis average data in rad with CRC	*9927C#	-0.015rad,9fee
Y axis average data in degrees with CRC	*9928C#	-0.97°,bbf4

CRC: see appendix 2.

The output for the raw data is in HEX, thus 0409 equals to 1033..

3.2.3 Commands for Temperature

Command description	Command	Output
Temperature raw data	*9941#	00a7
Temperature in Celsius	*9942#	28°C
Temperature in Fahrenheit	*9943#	82F
Temperature raw data with CRC	*9941#	00a2,672e
Temperature in Celsius with CRC	*9942#	30°C,189e
Temperature in Fahrenheit with CRC	*9943#	86F,f7de

CRC: see appendix 2.

The output for raw data is in HEX, thus 00a7 equals to 167.

3.2.4 Command 83: Perform self test

Command	Output	Comments
*9983#	Status Code: 0 & (line feed)	

3.2.5 Commands for configuration settings

3.2.5.1 Command 80: Read product info

Command	Output	Comments
*9980#	The Fredericks Co. 0750-XXXX Supportwww.Frederickscom.com Version 1.4.2 App level ABC Serial 12222222001 Temp coeffs 195 Ave samples 8 Sens 02.0V/g +/- XX Degrees	Product code Support e-mail address Program version Product level Serial number Temperature coefficients Number of samples in ave calculation Sensitivity & Range of sensor

3.2.5.2 Command 81: Change address

All modules are configured to address 99 when delivered (factory setting). The address can be changed via software when the module is installed as a part of a system . Please make sure that each module connected to same line has its individual address before installation. Two modules with same address will cause errors in operation.

Command	Output	Comments
*9981A25#	(line feed)	Use password: A The address is changed from 99 to 25

Note! The address is always given in two digits, e.g. address 3 is entered as 03.

3.2.5.3 Command 84: Change temperature coefficients

Command	Output	Comments
*9984t190#	(line feed)	Use password: t plus new room temp in C° (coeff changed automatically)

3.2.5.4 Command 85: Change the average rate

This parameter sets the number of samples that is used in the average calculations. The factory setting for the number of samples is 30.

Command	Output	Comments
*9985a10#	Old ave: 30 New ave: 10	Use password: a + new rate (Maximum number of samples is 100. There is 1ms delay between every sample taken.)

3.2.5.5 Command 86: Change X axis zero offset value

Command	Output	Comments
*99860#	(line feed)	Use password: 0 ('zero')

The offset can be adjusted in $\pm 5^\circ$ window

The method of adjustment:

- install the module in the final application or system
- make sure that the module is installed with $\pm 5^\circ$ accuracy of both the planned X axis and Y axis zero positions, and that the system is in rest
- enter the command above
- the module will now refer the position as its X axis zero offset position

3.2.5.6 Command 87: Change Y axis zero offset value

Command	Output	Comments
*99870#	(line feed)	Use password: 0 ('zero')

The offset can be adjusted in $\pm 5^\circ$ window
(x-value must be set first)

The method of adjustment:

- three first steps as in 4.3.4.6
- the module will now refer the position as its Y axis zero offset position

3.2.5.7 Command 88: Baud rate setting

The baud rate can be adjusted in the range of 1200...38400 baud

Command	Output	Comments
*9988R4#	(line feed)	Use password: R + code

The example above sets the baud rate to 9600 bauds. Note! Please also set the baud rate of the terminal software respectively because this change takes place immediately. The codes for baud rates are:

Code	Rate
1	1200
2	2400
3	4800
4	9600
5	19200
6	38400

NOTE: In case of communication problems, use 9600

3.2.6 Command 89: Factory reset



Command	Output	Comments
*9989B#	(line feed)	Use password: B



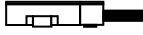
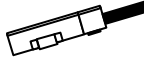

This replaces all user configurable values with factory setting. Note that there is no undo option.

4. TO BE NOTED WHEN MEASURING INCLINATION

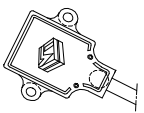
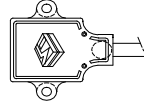
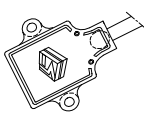
4.1 Important to note when installing the module

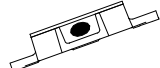
- First value can be asked after 1s from power on.
- It is important that the module is parallel to the mounting plane and that output equals the supplied zero value when sensor is in zero position.
- 1° mounting error from measuring plane will increase the cross-axis sensitivity by 1.7%
- The pictures below provide information on how the output of the accelerometer module behaves in different circumstances when installed. Please note that the part can be rotated around the measuring axis for optimum mounting location.

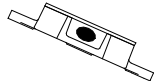
X axis	Positive inclination	Zero position	Negative inclination	Positive direction of gravity field
Alternative 1				
Alternative 2				

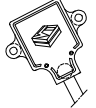
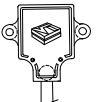
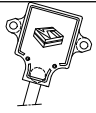
Y axis	Positive inclination	Zero position	Negative inclination	Positive direction of gravity field
Alternative 1				
Alternative 2				

Module positions

APPENDIX 1
List of commands

Command	Description	Comments	A	B	C
11	X axis raw data	Also with CRC by 11C	X	X	X
12	X axis data in mg	Also with CRC by 12C		X	X
13	X axis data in mrad	Also with CRC by 13C			X
14	X axis data in degrees	Also with CRC by 14C			X
15	X axis average raw data	Also with CRC by 15C		X	X
16	X axis average data in mg	Also with CRC by 16C		X	X
17	X axis average data in mrad	Also with CRC by 17C			X
18	X axis average data in degrees	Also with CRC by 18C			X
21	Y axis raw data	Also with CRC by 21C	X	X	X
22	Y axis data in mg	Also with CRC by 22C		X	X
23	Y axis data in mrad	Also with CRC by 23C			X
24	Y axis data in degrees	Also with CRC by 24C			X
25	Y axis average raw data	Also with CRC by 25C		X	X
26	Y axis average data in mg	Also with CRC by 26C		X	X
27	Y axis average data in mrad	Also with CRC by 27C			X
28	Y axis average data in degrees	Also with CRC by 28C			X
41	Temperature raw data	Also with CRC by 41C	X	X	X
42	Temperature in Celsius	Also with CRC by 42C		X	X
43	Temperature in Fahrenheit	Also with CRC by 43C		X	X
80	Send info		X	X	X
81	Change address of the module	Password 'A'	X	X	X
84	Change temperature coeffs	Password 't'		X	X
85	Change average rate	Password 'a'		X	X
86	Change X axis zero offset value	Password '0' ('zero')			X
87	Change Y axis zero offset value	Password '0' ('zero')			X
88	Baud rate setting 1200...38400	Password 'R'	X	X	X
89	Factory reset	Password 'B'	X	X	X

APPENDIX 2

Checksum (CRC16 Algorithm)

CRC16 (Cyclic Redundancy Codes) is used to for ensuring correct transmission of 16 bit digital word, especially when long or noisy transmission lines are used. 0750 modules use so called CRC16 calculation by polynomial $x^{16} + x^{15} + x^2 + 1$. Below is a short example C-code for calculating this check sum.

In the module commands with 'C' character (exc. 12C) counts CRC16 for all response characters before the last four hex chars. The last four hex characters are the 16bit CRC result. To check if there were any transmission errors calculate response before CRC with CRC16 algorithm and test it with CRC result found from end of the message. If these two are the same then there were no major errors in the transmissions (In some rare case there can be such a error that can't be seen on the test.).

Example C-code:

```
#define CRC16 0xA001 /* x16 + x15 + x2 + 1 */

uint16_t CRC16_calc (uint8_t data )
{
    uint8_t i;
    uint16_t crc = 0xffff;

    for ( i = 8; i; i-- )
    {
        if ( ( data ^ crc ) & 0x0001 )
            crc = ( crc >> 1 ) ^ CRC16;
        else
            crc >>= 1;
        data >>= 1;
    }
    return crc;
}
```